

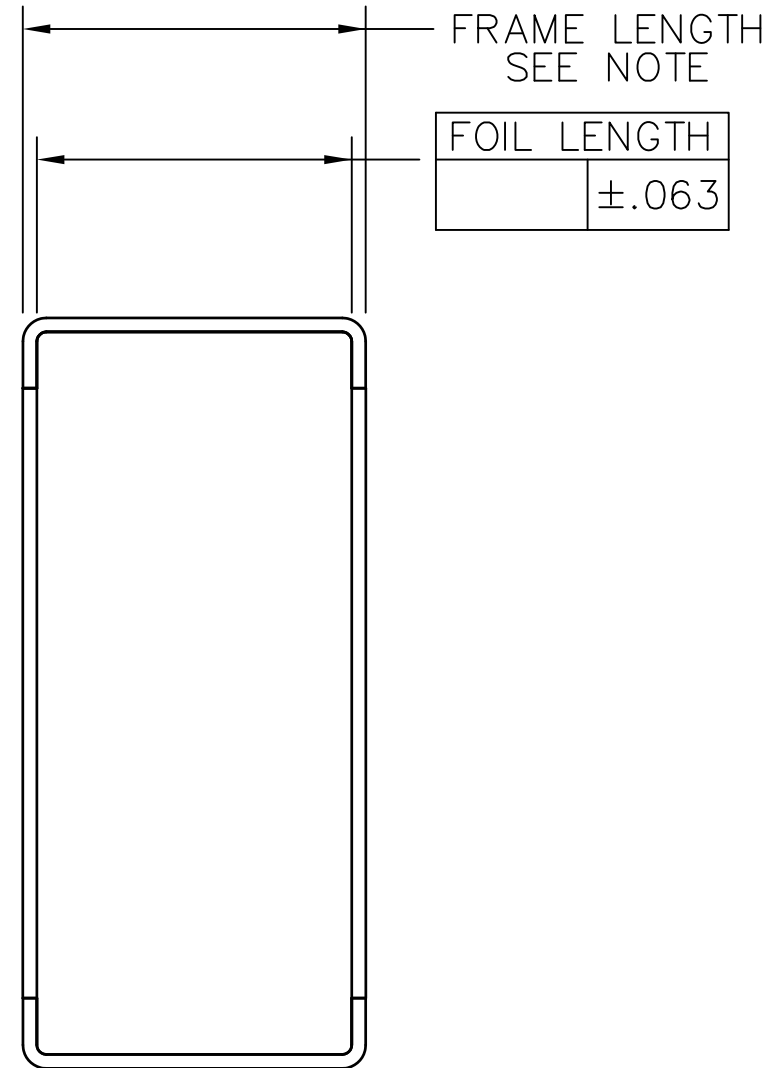

CUSTOMER APPROVAL: _____

TIG WELD ALONG SEAMS
GRIND FLUSH

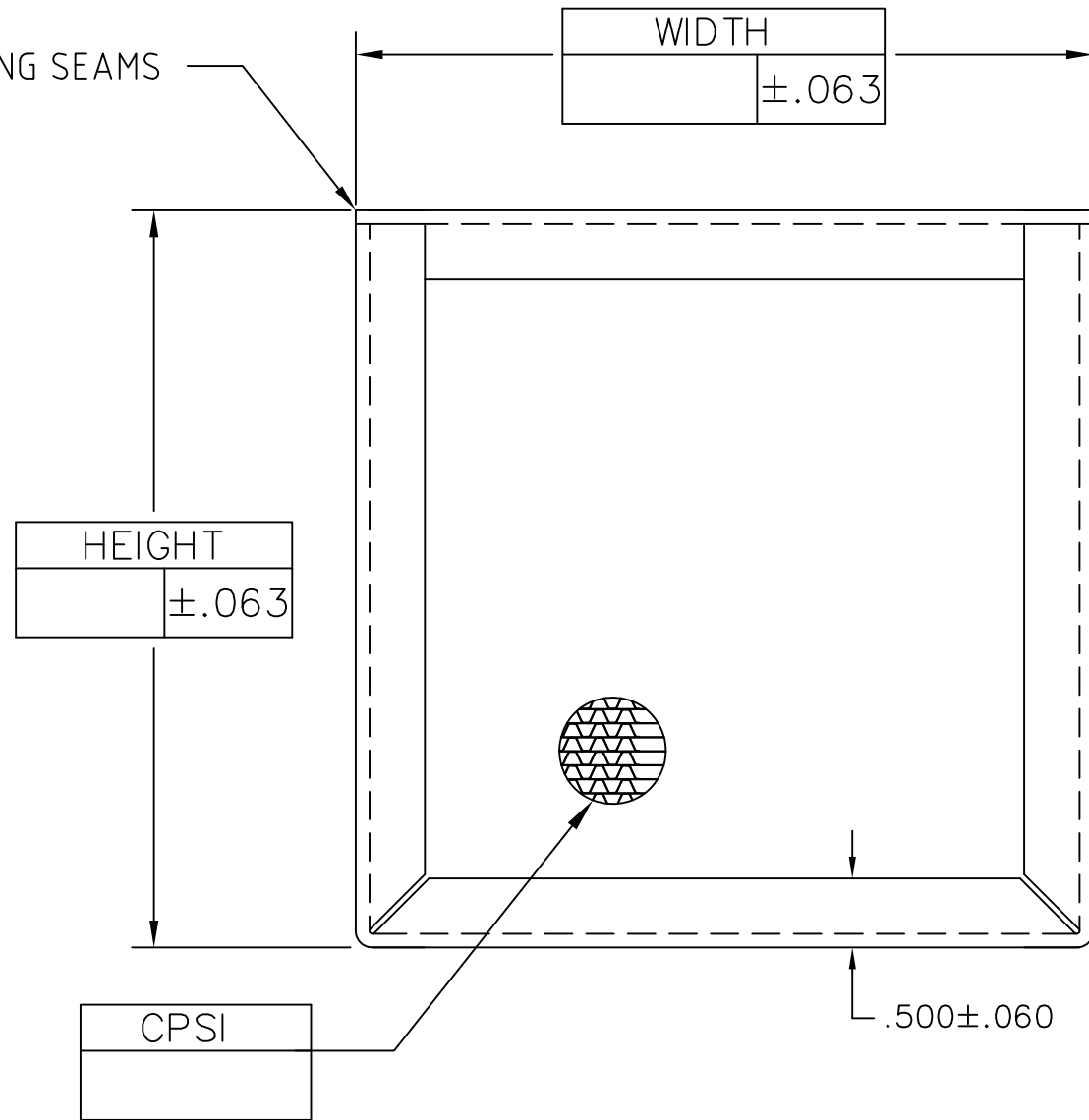

PACKAGING: EXTERIOR PACKAGING MUST INCLUDE LABEL WITH PART#, QTY & BRAZE LOT#
 PALLETS – LAYER OF CARDBOARD BTW FACES
 UPS/FedEx BOXES – ALL PARTS IN INDIVIDUAL BOX OR BUBBLE WRAP
 SAMPLING INSPECTION PLAN: C=0
 UNEVEN FOILS: 0.05 MAX BTW EDGE OF LAYERS
 DAMAGED CELLS/FACE DAMAGE: MAX 3% TOTAL FACIAL AREA
 FRAME: FREE OF BURRS AND OIL
 14 GA (.075”) THICK 430 SS, UNLESS OTHERWISE REQUESTED
 FRAME LENGTH = FOIL LENGTH +.18 ±.035
 FOILS: .002 THICK
 CELL DENSITY: $\pm 10\%$ ($2 / (\text{PEAK TO PEAK} \times \text{HEIGHT} = \text{CPSI})$)
 DELAMINATION: BETWEEN SUBSTRATE AND SUBSTRATE NO GREATER THAN CELL HEIGHT
 ALL DIMENSIONS IN INCHES

 PERFORMANCE INDUSTRIES			
SCALE: FULL	DATE:	SHEET 1 OF 1	
DRAWN BY: FWF	APP. BY:	REVISED:	
DESIGN FOR:		PART NAME:	
		PART NO:	
TITLE: RECTANGLE SUBSTRATE		DRAWING NO: PI-	TOOL NO: