

CUSTOMER APPROVAL: \_\_\_\_\_

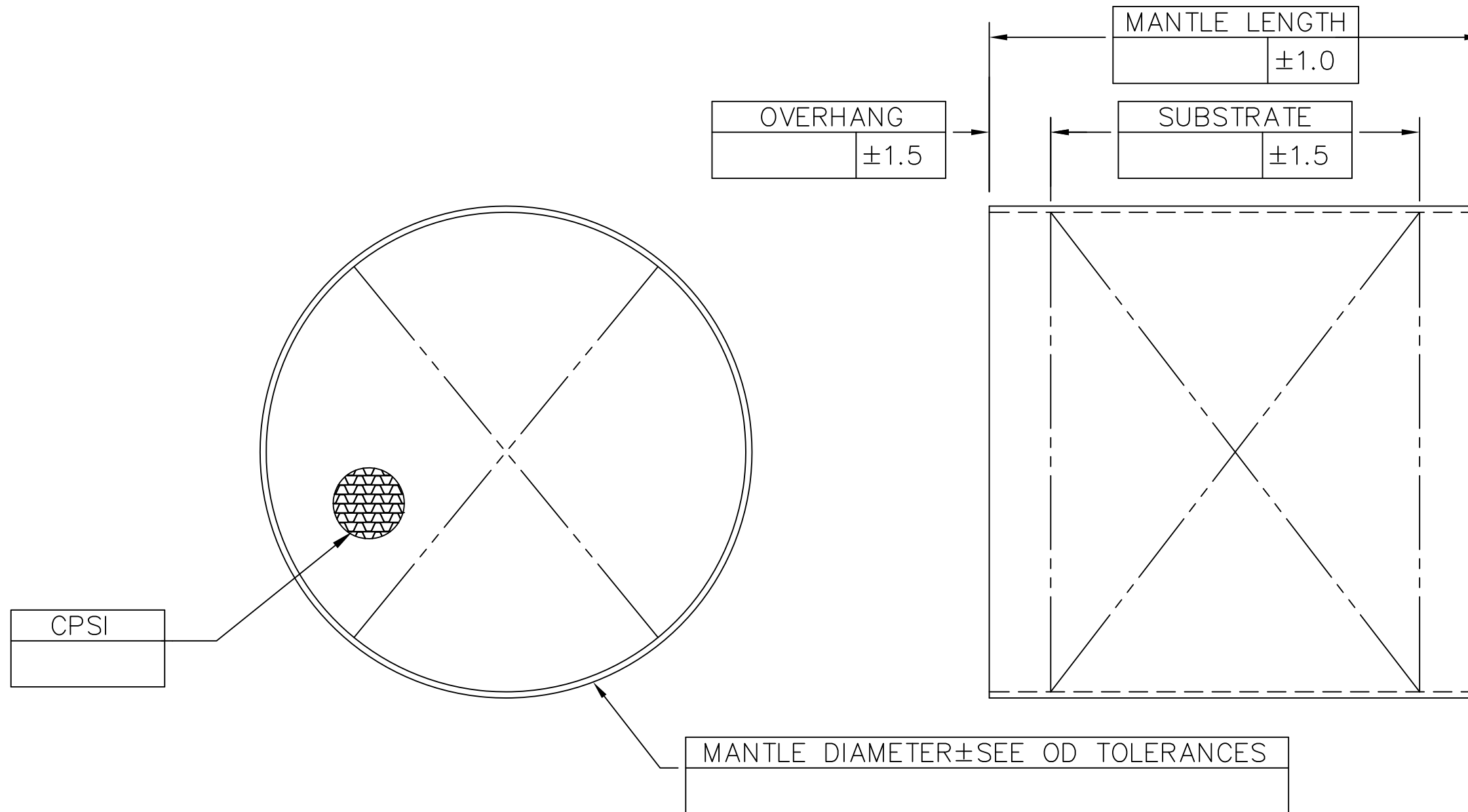

PACKAGING: EXTERIOR PACKAGING MUST INCLUDE LABEL WITH PART#, QTY & BRAZE LOT#  
 PALLETS – LAYER OF CARDBOARD BTW FACES  
 UPS/FedEx BOXES – ALL PARTS IN INDIVIDUAL BOX OR BUBBLE WRAP

SAMPLING INSPECTION PLAN: C=0  
 UNEVEN FOILS: 1.3mm MAX BTW EDGE OF LAYERS  
 DAMAGED CELLS/FACE DAMAGE: MAX 3% TOTAL FACIAL AREA  
 DEFECTS AND CELL DENSITY DOES NOT APPLY TO 6.4mm PERIMETER BAND AND CENTER 12.7 DIAMETER  
 MANTLE: < 127mm DIAMETER 16 GA (1.5mm) THICK 430 SS  
 GREATER THAN 127mm DIAMETER 14 GA (1.9mm) THICK 430 SS, UNLESS OTHERWISE REQUESTED  
 ID & OD FREE OF BURRS AND OIL  
 MANTLE CONSTRUCTION: GREATER THAN 6" COMPRESSION FIT W/BUTT JOINT WELDMENT  
 FOIL: .050 mm THICK  
 CELL DENSITY:  $\pm 10\%$  (2/(PEAK TO PEAK x HEIGHT=CPSI))  
 DELAMINATION: BETWEEN SUBSTRATE AND SUBSTRATE NO GREATER THAN CELL HEIGHT  
 BETWEEN MANTLE AND SUBSTRATE NO GREATER THAN 10% OF CIRCUMFERENCE

ALL DIMENSIONS IN mm

OD TOLERANCE	
SIZE (Ø)	DIAMETER
> 63.4	±1.1
63.5–368	±1.4
369–596	±1.7
597 <	±2.5

 <b>PERFORMANCE INDUSTRIES</b>			
SCALE: FULL	DATE:	SHEET 1 OF 1	
DRAWN BY: FWF	APP. BY:	REVISED:	
DESIGN FOR:		PART NAME:	
		PART NO:	
TITLE: MANTLED ROUND SUBSTRATE W/ OVERHANG		DRAWING NO: PI-	TOOL NO: