

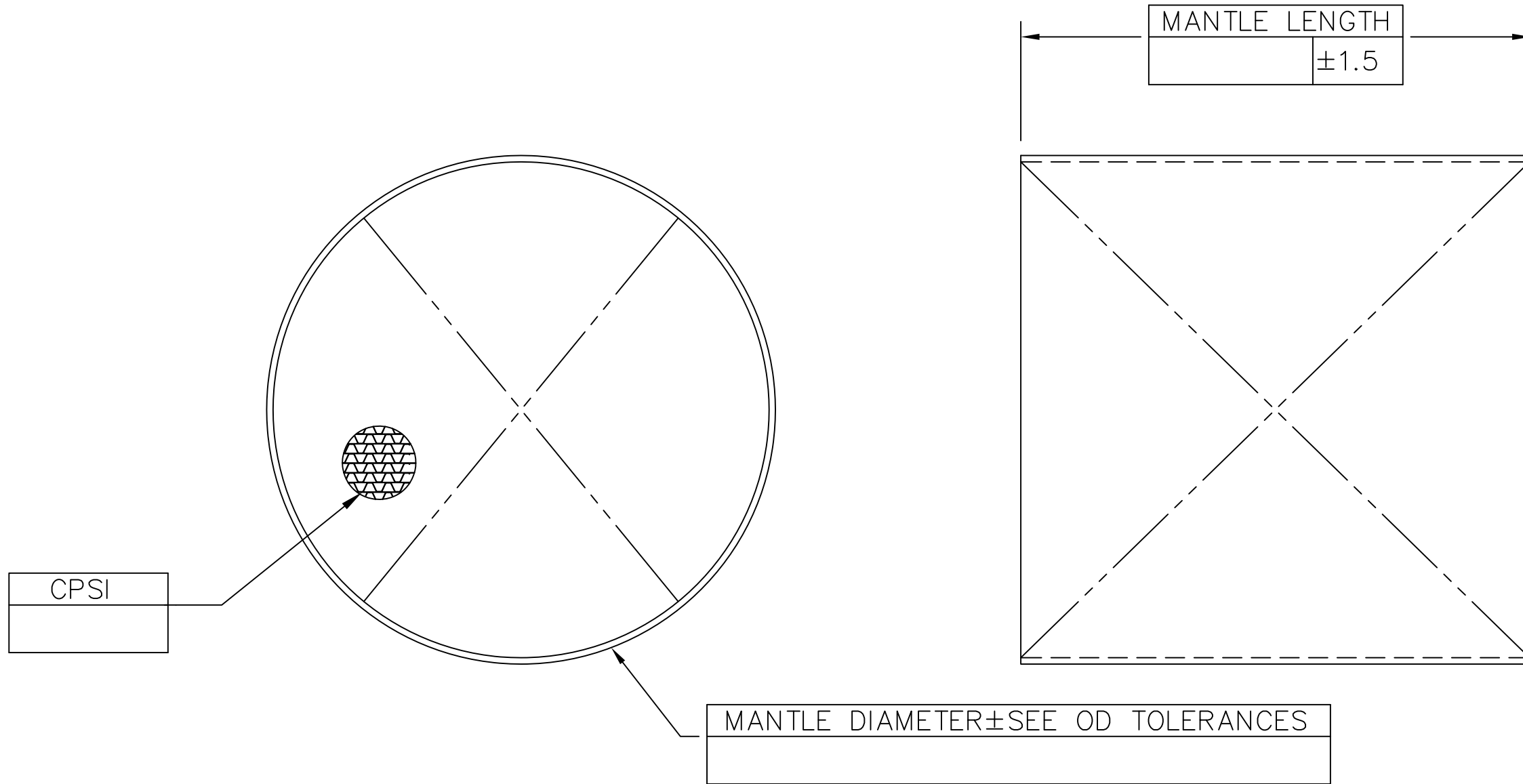

CUSTOMER APPROVAL: _____



PACKAGING: EXTERIOR PACKAGING MUST INCLUDE LABEL WITH PART#, QTY & BRAZE LOT#
 PALLETS – LAYER OF CARDBOARD BTW FACES
 UPS/FedEx BOXES – ALL PARTS IN INDIVIDUAL BOX OR BUBBLE WRAP
 SAMPLING INSPECTION PLAN: C=0
 UNEVEN FOILS: 1.3mm MAX BTW EDGE OF LAYERS
 DAMAGED CELLS/FACE DAMAGE: MAX 3% TOTAL FACIAL AREA
 DEFECTS AND CELL DENSITY DOES NOT APPLY TO 6.4mm PERIMETER BAND AND CENTER 12.7 DIAMETER
 MANTLE: < 127mm DIAMETER 16 GA (1.5mm) THICK 430 SS
 GREATER THAN 127mm DIAMETER 14 GA (1.9mm) THICK 430 SS, UNLESS OTHERWISE REQUESTED
 ID & OD FREE OF BURRS AND OIL
 MANTLE CONSTRUCTION: GREATER THAN 6" COMPRESSION FIT W/BUTT JOINT WELDMENT
 FOIL: .05mm THICK
 CELL DENSITY: $\pm 10\%$ ($2 / (\text{PEAK TO PEAK} \times \text{HEIGHT} = \text{CPSI})$)
 DELAMINATION: BETWEEN SUBSTRATE AND SUBSTRATE NO GREATER THAN CELL HEIGHT
 BETWEEN MANTLE AND SUBSTRATE NO GREATER THAN 10% OF CIRCUMFERENCE
 ALL DIMENSIONS IN mm

OD TOLERANCE	
SIZE (∅)	DIAMETER
> 63.4	±1.1
63.5–368	±1.4
369–596	±1.7
597 <	±2.5

 PERFORMANCE INDUSTRIES			
SCALE: FULL	DATE:	SHEET 1 OF 1	
DRAWN BY: FWF	APP.BY:	REVISED:	
DESIGN FOR:		PART NAME:	
		PART NO:	
TITLE: MANTLED ROUND SUBSTRATE		DRAWING NO: PI-	TOOL NO: