

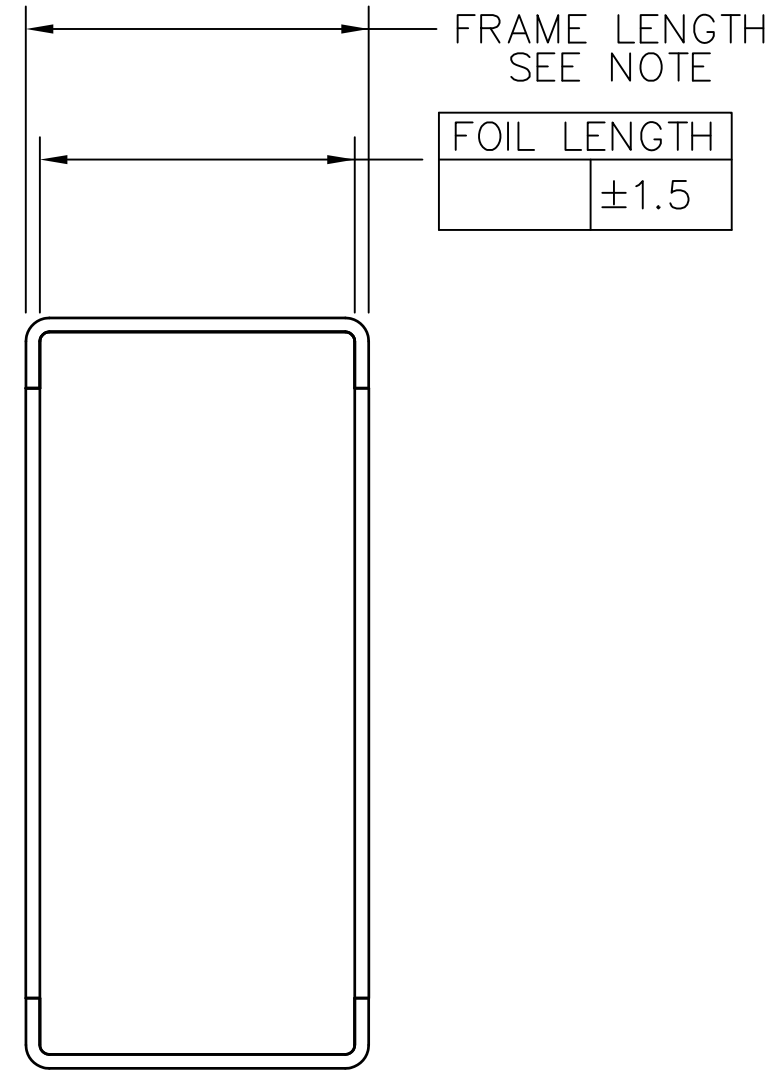

CUSTOMER APPROVAL: _____

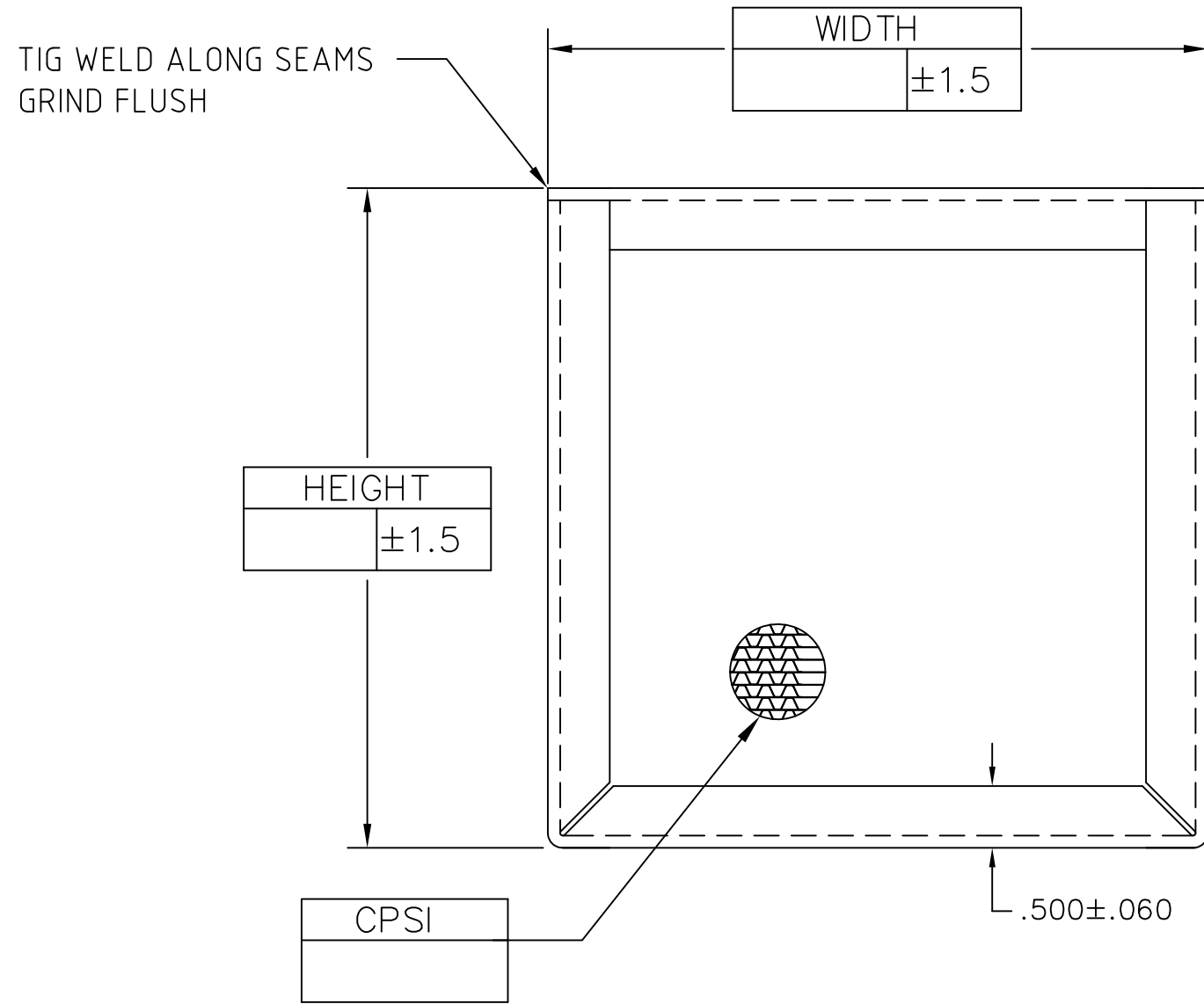

PACKAGING: EXTERIOR PACKAGING MUST INCLUDE LABEL WITH PART#, QTY & BRAZE LOT#
 PALLETS – LAYER OF CARDBOARD BTW FACES
 UPS/FedEx BOXES – ALL PARTS IN INDIVIDUAL BOX OR BUBBLE WRAP
 SAMPLING INSPECTION PLAN: C=0
 UNEVEN FOILS: 0.05 MAX BTW EDGE OF LAYERS
 DAMAGED CELLS/FACE DAMAGE: MAX 3% TOTAL FACIAL AREA
 FRAME: FREE OF BURRS AND OIL
 14 GA (1.9”) THICK 430 SS, UNLESS OTHERWISE REQUESTED
 CHANNEL WIDTH = FOIL LENGTH +4.2 ±.9
 FOILS: .050mm THICK
 CELL DENSITY: ±10% (2/(PEAK TO PEAK x HEIGHT=CPSI)
 DELAMINATION: BETWEEN SUBSTRATE AND SUBSTRATE NO GREATER THAN CELL HEIGHT
 ALL DIMENSIONS IN mm

 PERFORMANCE INDUSTRIES			
SCALE: FULL	DATE:	SHEET 1 OF 1	
DRAWN BY: FWF	APP.BY:	REVISED:	
DESIGN FOR:		PART NAME:	
		PART NO:	
TITLE: RECTANGLE SUBSTRATE		DRAWING NO: PI-	TOOL NO: