

CUSTOMER APPROVAL: _____

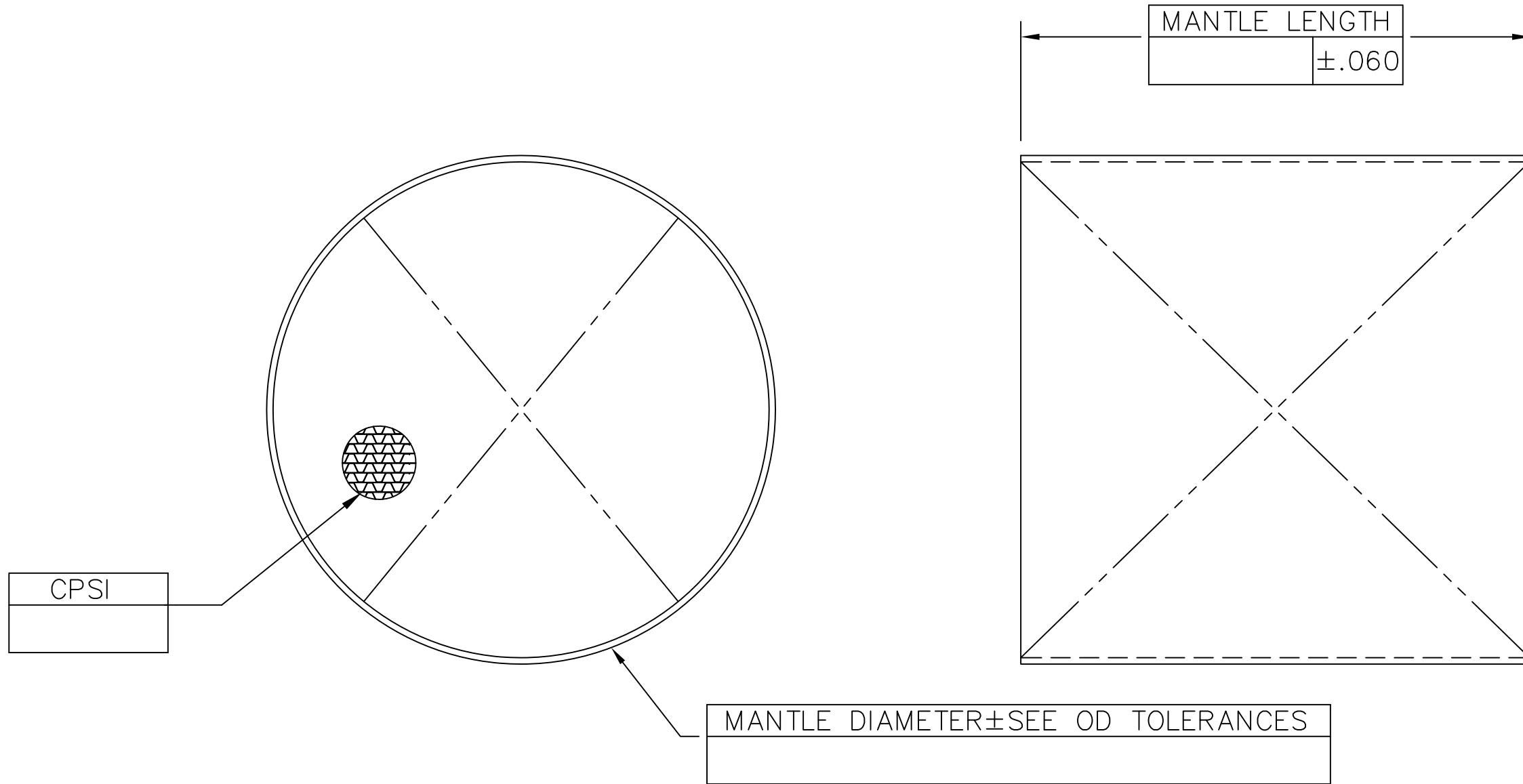

PACKAGING: EXTERIOR PACKAGING MUST INCLUDE LABEL WITH PART#, QTY & BRAZE LOT#
 PALLETS – LAYER OF CARDBOARD BTW FACES
 UPS/FedEx BOXES – ALL PARTS IN INDIVIDUAL BOX OR BUBBLE WRAP

SAMPLING INSPECTION PLAN: C=0
 UNEVEN FOILS: 0.05 MAX BTW EDGE OF LAYERS
 DAMAGED CELLS/FACE DAMAGE: MAX 3% TOTAL FACIAL AREA
 DEFECTS AND CELL DENSITY DOES NOT APPLY TO .250 INCH PERIMETER BAND AND CENTER .500 INCH DIAMETER
 MANTLE: ID & OD FREE OF BURRS AND OIL
 14 GA (.075”) THICK 430 SS, UNLESS OTHERWISE REQUESTED
 MANTLE CONSTRUCTION: GREATER THAN 6” COMPRESSION FIT W/BUTT JOINT WELDMENT
 FOIL: .002 THICK
 CELL DENSITY: $\pm 10\%$ ($2 / (\text{PEAK TO PEAK} \times \text{HEIGHT} = \text{CPSI})$)
 DELAMINATION: BETWEEN SUBSTRATE AND SUBSTRATE NO GREATER THAN CELL HEIGHT
 BETWEEN MANTLE AND SUBSTRATE NO GREATER THAN 10% OF CIRCUMFERENCE

ALL DIMENSIONS IN INCHES

OD TOLERANCE	
SIZE (∅)	DIAMETER
.75–2.49	±.040
2.5–14.4	±.050
14.5–23.4	±.063
23.5+	±.094

 PERFORMANCE INDUSTRIES			
SCALE: FULL	DATE:	SHEET 1 OF 1	
DRAWN BY: FWF	APP.BY:	REVISED:	
DESIGN FOR:		PART NAME:	
		PART NO:	
TITLE: MANTLED ROUND SUBSTRATE		DRAWING NO: PI-	TOOL NO: