

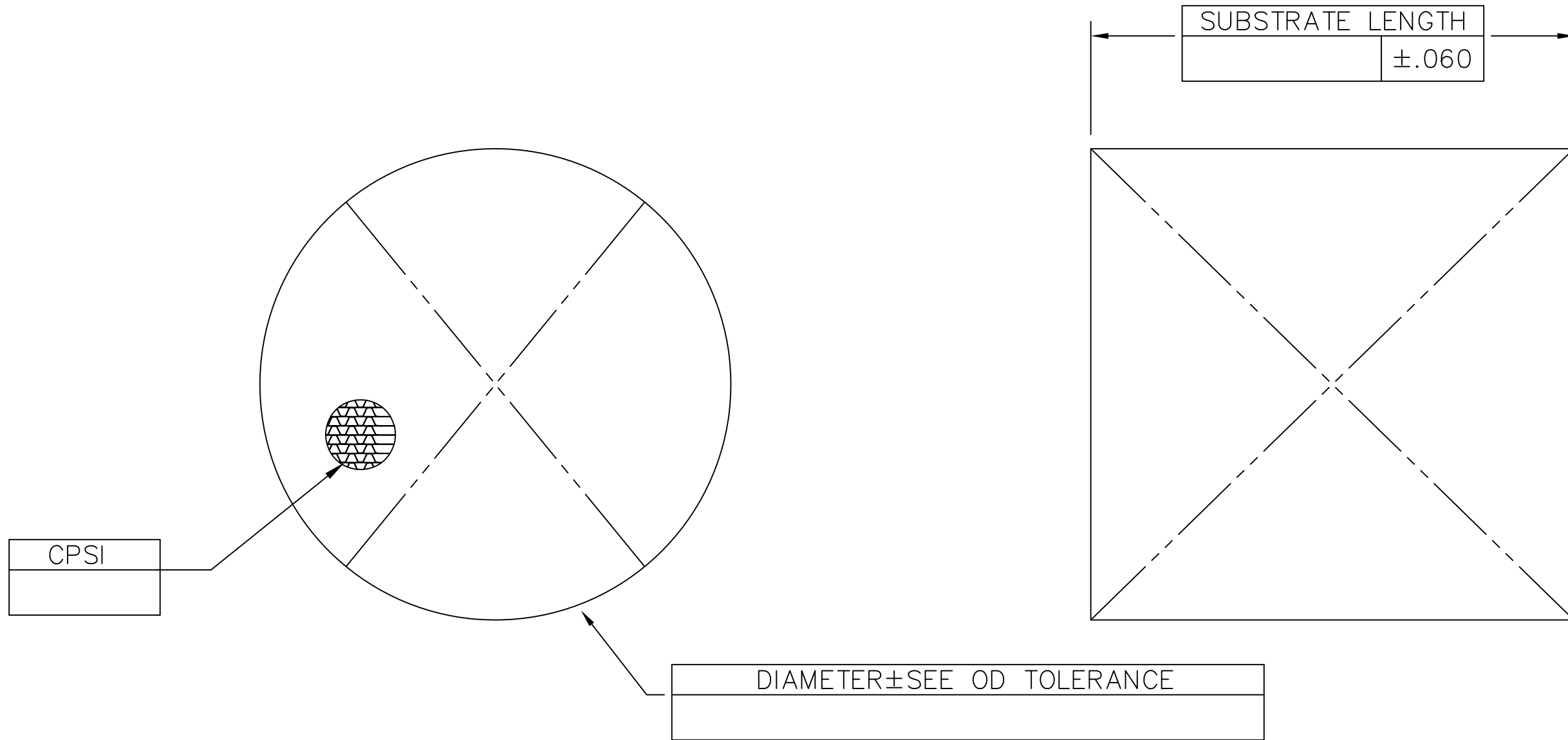

CUSTOMER APPROVAL: \_\_\_\_\_



PACKAGING: EXTERIOR PACKAGING MUST INCLUDE LABEL WITH PART#, QTY & BRAZE LOT#  
 PALLETS – LAYER OF CARDBOARD BTW FACES  
 UPS/FedEx BOXES – ALL PARTS IN INDIVIDUAL BOX OR BUBBLE WRAP  
 SAMPLING INSPECTION PLAN: C=0  
 UNEVEN FOILS: 0.05 MAX BTW EDGE OF LAYERS  
 DAMAGED CELLS/FACE DAMAGE: MAX 3% TOTAL FACIAL AREA  
 DEFECTS AND CELL DENSITY DOES NOT APPLY TO .250 INCH PERIMETER BAND AND CENTER .500 INCH DIAMETER  
 FOILS: .002 THICK  
 CELL DENSITY:  $\pm 10\%$  ( $2 / (\text{PEAK TO PEAK} \times \text{HEIGHT} = \text{CPSI})$ )  
 DELAMINATION: BETWEEN SUBSTRATE AND SUBSTRATE NO GREATER THAN CELL HEIGHT  
 ALL DIMENSIONS IN INCHES

OD TOLERANCE	
SIZE ( $\phi$ )	DIAMETER
.75–2.49	$\pm.040$
2.5–14.4	$\pm.050$
14.5–23.4	$\pm.063$
23.5+	$\pm.094$

 <b>PERFORMANCE INDUSTRIES</b>			
SCALE: FULL	DATE:	SHEET 1 OF 1	
DRAWN BY: FWF	APP. BY:	REVISED:	
DESIGN FOR:		PART NAME:	
		PART NO:	
TITLE: ROUND SUBSTRATE		DRAWING NO: PI-	TOOL NO: